

United States of America  
Department of Transportation -- Federal Aviation Administration  
**Supplemental Type Certificate**

*Number* SA702GL

*This certificate issued to* Aero Cables Corp.  
11953 S. Spaulding School Road  
Unit 2  
Plainfield, IL 60544

*certifies that the change in the type design for the following product with the limitations and conditions therefor as specified hereon meets the airworthiness requirements of Part 3 of the Civil Air Regulations.*  
(See Type Certificate Data Sheet No. 3A12 for complete certification basis.)

*Original Product - Type Certificate Number :* 3A12  
*Make :* Cessna Aircraft Company  
*Model :* 172K, 172L, 172M, 172N, 172P, 172Q

*Description of Type Design Change:*

Installation of a Cooling Shroud on engine driven dry air pumps in accordance with S & M Products Report S & M 1, Revision 02, dated August 12, 1983 or subsequent FAA approved revision.

*Limitations and Conditions :*

- 1) Compatibility of this design change with previously approved modifications must be determined by the installer.
- 2) If the holder agrees to permit another person to use this certificate to alter the product, the holder shall give the other person written evidence of that permission.

*This certificate and the supporting data which is the basis for approval shall remain in effect until surrendered, suspended, revoked or a termination date is otherwise established by the Administrator of the Federal Aviation Administration.*

*Date of application :* August 12, 1983

*Date reissued :* March 19, 2004; June 15, 2004

*Date of issuance :* August 26, 1983

*Date amended :*

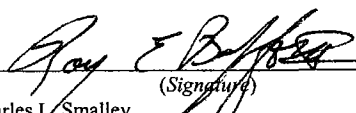

*By direction of the Administrator*

  
(Signature)  
Charles L. Smalley  
Manager, Systems and Flight Test Branch  
Chicago Aircraft Certification Office

(Title)



S&M Report No. 1  
Revision 05  
February 25, 1985

KIT NO. 10 - Vacuum Pump Cooling Kit for Airborne Model 200 thru 212CW and CC Dry  
Air Pumps  
KIT NO. 11 - Vacuum Pump Cooling Kit for EDO-AIRE Model 1U128, 1U128A and 1U128B;  
and SIGMA TEK Model 1U128B Dry Air Pumps

Cessna 172 Series, TC 3A12

REVISION PAGE

<u>Table of Contents</u>	<u>Page No.</u>	<u>Revision/Date</u>
Revision Page	1	05, 02-25-85
Kit No. 10 and Kit No. 11 Parts List	2	05, 02-25-85
Drawing List for Kit No. 10 and Kit No. 11	3	05, 02-25-85
Installation Instructions	4 & 5	05, 02-25-85
Drawing B (Cessna 172K thru 172Q)	5	05, 02-25-85
Drawing Q (View of Cooling Kit on Airborne Pump)	6	03, 12-16-83
Drawing R (View of Cooling Kit on EDO-AIRE and SIGMA TEK Pumps)	7	05, 02-25-85
Material Specifications	8	05, 02-25-85
Drawing, Cooling Shroud Model 2CDH	9	03, 12-16-83
Drawing, Cooling Shroud Model 4ADH	10	05, 02-25-85
Test Plan	11	01, 07-11-83
STC and Eligibility Listing	12	05, 02-25-85

FAA  
APPROVED

MAR 15 1985

CHICAGO AIRCRAFT  
CERTIFICATION OFFICE  
CENTRAL REGION  
ACE-130C  
nkr/ndp

S&M Report No. 1  
Revision 05  
February 25, 1985

KIT NO. 10 - Vacuum Pump Cooling Kit for Airborne Model 200 thru 212CW and CC Dry Air Pumps

KIT NO. 11 - Vacuum Pump Cooling Kit for EDO-AIRE Model 1U128, 1U128A and 1U128B; and SIGMA TEK Model 1U128B Dry Air Pumps

Cessna 172 Series, TC 3A12

REVISION PAGE

<u>Table of Contents</u>	<u>Page No.</u>	<u>Revision/Date</u>
Revision Page	1	05, 02-25-85
Kit No. 10 and Kit No. 11 Parts List	2	05, 02-25-85
Drawing List for Kit No. 10 and Kit No. 11	3	05, 02-25-85
Installation Instructions	4 & 5	05, 02-25-85
Drawing B (Cessna 172K thru 172Q)	5	05, 02-25-85
Drawing Q (View of Cooling Kit on Airborne Pump)	6	03, 12-16-83
Drawing R (View of Cooling Kit on EDO-AIRE and SIGMA TEK Pumps)	7	05, 02-25-85
Material Specifications	8	05, 02-25-85
Drawing, Cooling Shroud Model 2CDH	9	03, 12-16-83
Drawing, Cooling Shroud Model 4ADH	10	05, 02-25-85
Test Plan	11	01, 07-11-83
STC and Eligibility Listing	12	05, 02-25-85

S&M Report No. 1  
Revision 05  
February 25, 1985

KIT NO. 10 - Vacuum Pump Cooling Kit for Airborne Model 200 thru 212CW and CC Dry Air Pumps

KIT NO. 11 - Vacuum Pump Cooling Kit for EDO-AIRE Model 1U128, 1U128A and 1U128B; and SIGMA TEK Model 1U128B Dry Air Pumps

Cessna 172 Series, TC 3A12

KIT NO. 10 PARTS LIST - AIRBORNE INSTALLATION

<u>Quantity</u>	<u>Part No.</u>	<u>Description</u>
1	2CDH	Cooling Shroud
1	2CDH-1	Flange
1	2CDH-2	Approx 13.3" C.A.T. Aeroduct Tubing
2	2CDH-3	Cable Ties
1	Rev. 05, 02-25-85	Installation Instructions
1	Rev. 05, 02-25-85	Flange Installation Drawings
1	Rev. 03, 12-16-83	Kit Installation Drawing (View of Cooling Kit on Pump)
1	Rev. 05, 02-25-85	STC and Eligibility Listing

KIT NO. 11 PARTS LIST - EDO-AIRE & SIGMA TEK INSTALLATION

<u>Quantity</u>	<u>Part No.</u>	<u>Description</u>
1	4ADH	Cooling Shroud
1	4ADH-1	Flange
1	4ADH-2	Approx 17" C.A.T. Aeroduct Tubing
2	4ADH-3	Cable Ties
1	Rev. 05, 02-25-85	Installation Instructions
1	Rev. 05, 02-25-85	Flange Installation Drawings
1	Rev. 05, 02-25-85	Kit Installation Drawing (View of Cooling Kit on Pump)
1	Rev. 05, 02-25-85	STC and Eligibility Listing

S&M Report No. 1  
Revision 05  
February 25, 1985

KIT NO. 10 - Vacuum Pump Cooling Kit for Airborne Model 200 thru 212CW and CC Dry Air Pumps  
KIT NO. 11 - Vacuum Pump Cooling Kit for EDO-AIRE Model 1U128, 1U128A and 1U128B; and SIGMA TEK Model 1U128B Dry Air Pumps

Cessna 172 Series, TC 3A12

DRAWING LIST FOR KIT NO. 10 & KIT NO. 11

<u>Drawing</u>	<u>Description</u>	<u>Page No.</u>
B	CESSNA 172K thru 172Q - Flange installation location and measurements.	5
Q	View of Cooling Shroud on Airborne Pump, Ducting and Flange (KIT NO. 10)	6
R	View of Cooling Shroud on EDO-AIRE and SIGMA TEK Pump, Ducting and Flange (KIT NO. 11)	7

S&M Report No. 1  
Revision 05  
February 25, 1985

KIT NO. 10 - Vacuum Pump Cooling Kit for Airborne Model 200 thru 212CW and CC Dry Air Pumps

KIT NO. 11 - Vacuum Pump Cooling Kit for EDO-AIRE Model 1U128, 1U128A and 1U128B; and SIGMA TEK Model 1U128B Dry Air Pumps

Cessna 172 Series, TC 3A12

#### INSTALLATION INSTRUCTIONS

1. To install Vacuum Pump Cooling Kit No. 10 on Airborne Model 200 thru 212CW and CC Dry Air Pumps, or Vacuum Pump Cooling Kit No. 11 on EDO-AIRE Model 1U128, 1U128A, 1U128B, and SIGMA TEK Model 1U128B Dry Air Pumps installed on the aircraft shown above, proceed according to the following instructions and refer to Flange Installation Drawing B. For a view of the cooling shroud, ducting and flange, refer to Drawing Q for Kit No. 10 and Drawing R for Kit No. 11.

#### 2. COOLING SHROUD INSTALLATION.

a. To mount the cooling shroud on the vacuum pump, the shroud must be held open slightly while installing. The shroud is made so the cooling exit is not centered with the cooling inlet. Turn over and/or rotate the shroud on the vacuum pump to best compromise the cooling inlet and outlet with other objects that may interfere with them near and around the vacuum pump.

b. On the Airborne installation (Kit No. 10), the shroud may not be able to be slipped on the pump and rotated to the desired position because of interference with other parts. In this case, remove the rear fitting on the pump, slip the shroud on and rotate it, then reinstall the rear fitting. If lubrication of the fitting is needed, use only a spray silicone on the threads, shake off the excess and let it dry before installing the fitting. **DO NOT** use oil, grease or tape on the threads.

c. Optional Shroud Position on Lycoming Engines. Due to tachometer drive interference on some Lycoming engines, an optional position on the shroud may be 1/8" toward the undriven end of the pump, or the shroud can be filed to allow the shroud to center on the pump. **DO NOT** file through the shroud.

3. COOLING DUCT INSTALLATION. Install the cooling duct on the shroud inlet using sealant and a nylon cable tie, as per instructions on Drawing Q or R, as applicable. Route the cooling duct to the aft side of the rear engine baffle, avoiding sharp bends, sharp objects and moving parts. Do not cut off excess duct at this time.

#### 4. INSTALLATION OF FLANGE FITTING. (Refer to Drawing B)

a. Make a 1 1/8" hole in the baffle, maintaining a 1" edge distance minimum, or as per drawing.

b. Drill four (4) #40 holes and use washers under rivets on flange side. Install the flange through the baffle from the front. Use sealant between flange and baffle. Install the flanged fitting using four (4) AN470AD-3 rivets or drill four (4) #28 holes and use four (4) AN526-632 screws and AN365-632 nuts and AN960-6 washers.

Installation Instructions (Continued):

c. Cut the cooling duct to length--avoid making it too long or too short for best routing. Try to avoid making over 90 degree bends and sharp bends.

d. Install the cooling duct on the flanged fitting using sealant and a nylon cable tie (see Drawing Q or R). Support or tie the cooling duct every 12 inches.

5. SEALING REQUIREMENTS.

a. To compensate for the 7/8" hole in the rear engine baffle, seal holes in the engine baffling at forward and rear corners, the space between the rear baffle and the engine crankcase, where sheet metal corners have holes in them, and where hoses and wires pass through the baffling. Seal enough holes and gaps to exceed .601 square inch, or 1/8" x 5", or 1/4" x 2.5".

b. Use 890 or RTV 106 red high temperature sealants per manufacturers' instructions. Alternate sealants are GE RTV 102, 103, 108, 158; Dow Corning 732 RTV sealants; or equivalents.

6. PAPERWORK.

a. Add the appropriate cooling kit number to the aircraft equipment list.

b. Weight of this kit is .24 lbs.

c. Complete FAA Form 337 and make proper logbook entry of kit installation.

CESSNA 172N, TC 3A12

CESSNA 172K, L, M, P, Q, TC 3A12

Edge of flange against  
5th and 6th rivets.

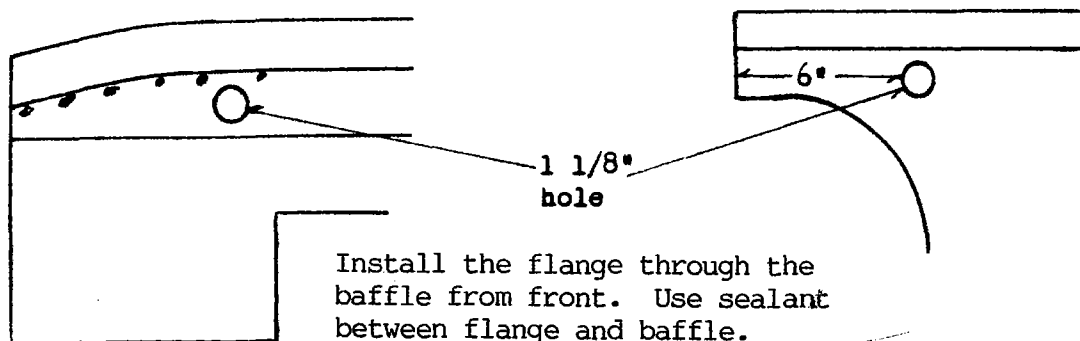

View: L H rear engine baffle,  
looking forward

View: R H rear engine baffle,  
looking forward

Note: Protect tubing from chafing against engine mount in back of baffle. (Suggest using sealant specified above to coat tubing and engine mount, but do not glue together.)



KIT NO. 10  
View of Cooling Shroud on AIRBORNE Pump, Ducting & Flange

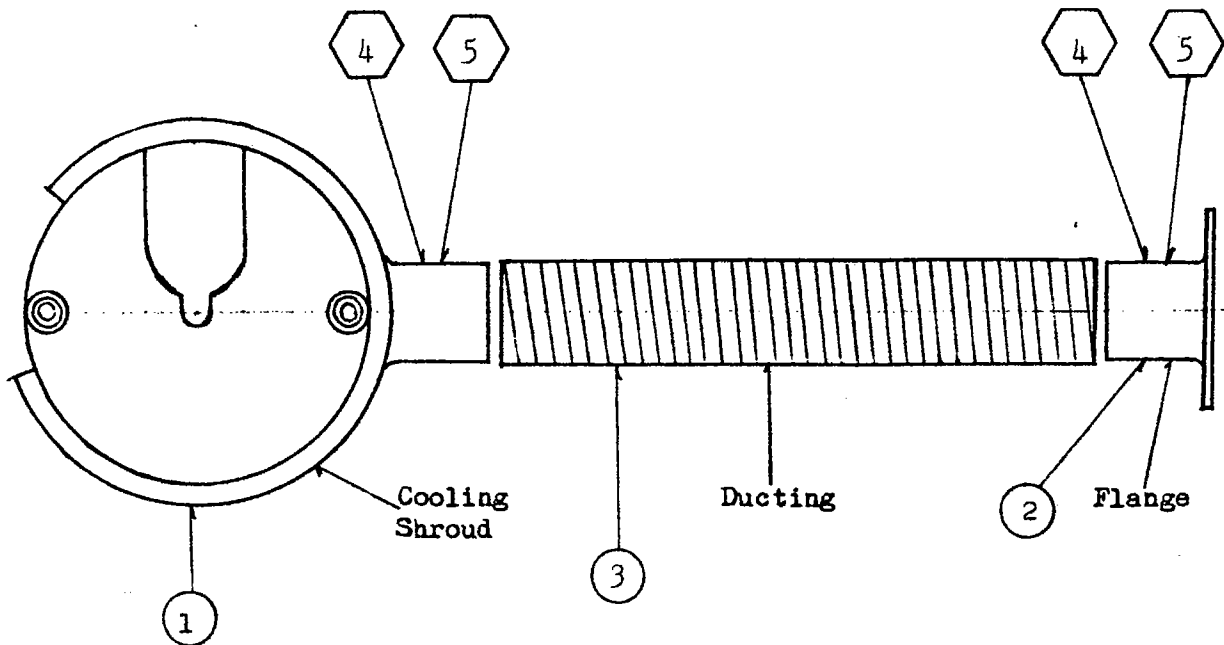

Note: Shroud must be centered on the pump.

FAA  
APPROVED

DEC 20 1983

CHICAGO AIRCRAFT  
CERTIFICATION OFFICE  
CENTRAL REGION

ACE 130C  
MK Dahl

4 Cable Ties - Attach these around ducting at inlet of shroud and outlet of flange after ducting has been sealed into place on the inlet and outlet.

5 Sealant - Place sealant on outside of shroud inlet and flange outlet, then push ducting into place. For type of sealant to be used, refer to paragraph 5b of Installation Instructions.

Item	Qty	Nomenclature	Part No.
5	A/R	Sealant	
4	2	Cable Ties	2CDH-3
3	A/R	Ducting	2CDH-2
2	1	Flange	2CDH-1
1	1	Shroud	2CDH

*Drawing Q*

S&M PRODUCTS  
2515 E. Bonnie Brook Lane  
Waukegan, IL 60087  
Rev. 03 Date: 12/16/83

S&M Report No. 1  
 Revision 05  
 February 25, 1985

KIT NO. 11

View of Cooling Shroud on EDO-AIRE & SIGMA TEK Pumps, Ducting & Flange

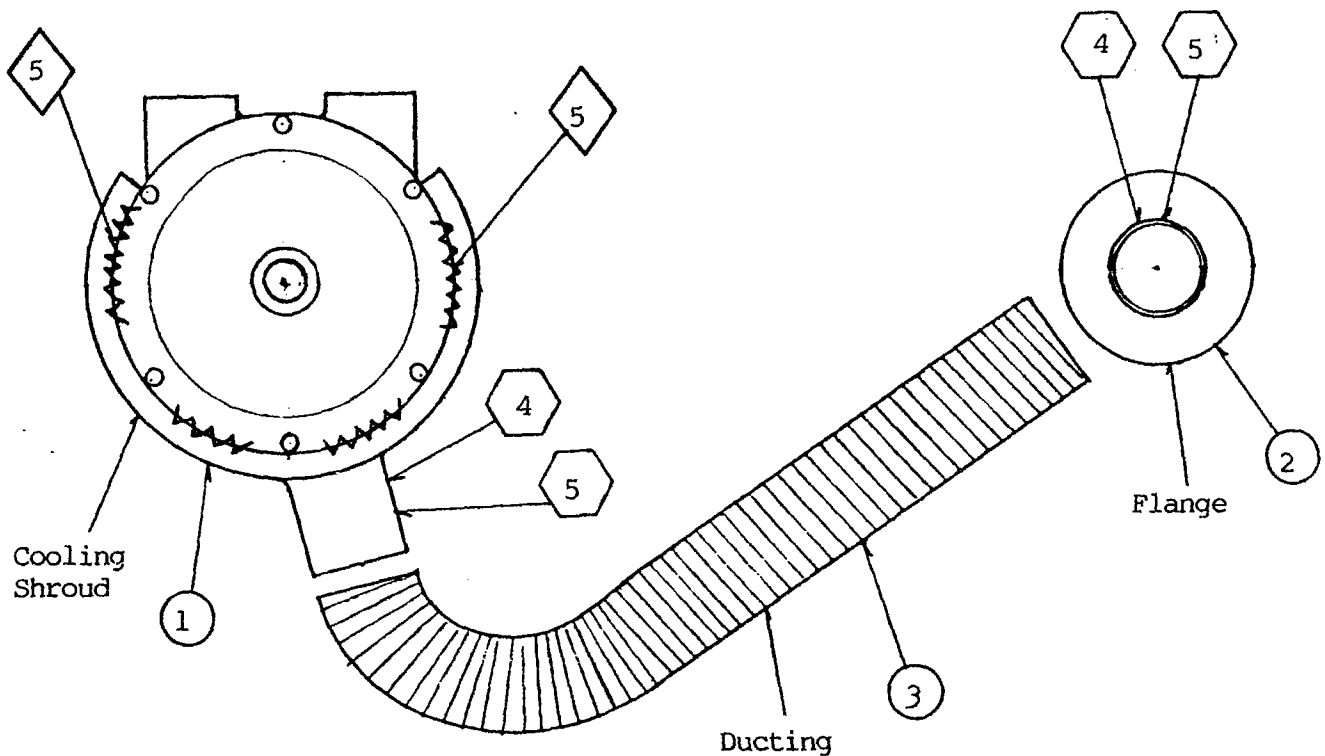

Note: Shroud must be centered on the pump. On some installations the pump may have to be rotated on the mounting pad because of interference with other objects.

- 4 Cable Ties - Attach these around ducting at inlet of shroud and outlet of flange after ducting has been sealed into place on the inlet and outlet.
- 5 Sealant - Place sealant on outside of shroud inlet and flange outlet, then push ducting into place. For type of sealant to be used, refer to paragraph 5b of Installation Instructions.
- 5 Apply sealant fillet between shroud and pump, at the rear of the pump, as shown, to prevent shifting of shroud on pump.

**DRAWING R**

Item	Qty	Nomenclature	Part No.
5	A/R	Sealant	
4	2	Cable Ties	4ADH-3
3	A/R	Ducting	4ADH-2
2	1	Flange	4ADH-1
1	1	Shroud	4ADH

S&M PRODUCTS  
 2515 E. Bonnie Brook Lane  
 Waukegan, IL 60087

Rev. 05 Date: 02-25-85